

# Revox Invisible Speaker

## TECHNICAL DATA SHEET

### INV HEX

Invisible speaker for bonding to hard surfaces such as plastic, wood or aluminum composite panels. Transforms vibrating surfaces such as plant pots or back walls in the bathroom/kitchen area into invisible loudspeakers by gluing them to the back. Wooden elements (possibly with pocket milling) in the furniture sector are also a suitable area of application. Thanks to its compact design and its special cone with high efficiency, the INV HEX is very versatile.

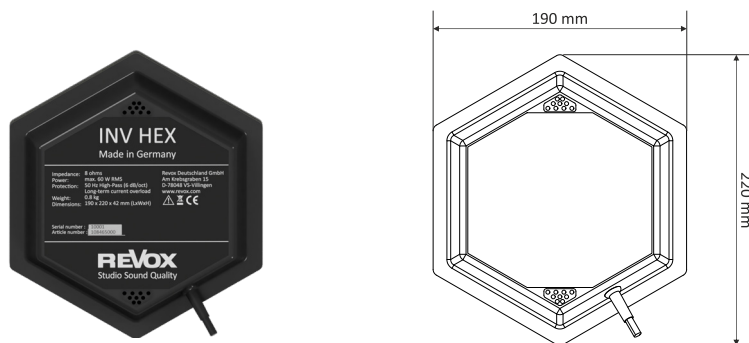

### TECHNICAL DATA

	INV HEX
Order no.	108465000
Dimensions L x W x D (mm)	190 x 220 x 40
Minimum installation depth (mm)	40
Weight (kg)	0,6
Capacity (Watt)	max. 60W RMS
Impedance (Ohm)	8
Sensitivity	85 dB/1W/1m
Frequency range (-6 dB)	60 Hz - 15 kHz
Connection cable	1m incl. WAGO connection clamps
Outdoor suitable	✓ (with INV HEX Cover)

### ACCESSORIES

	incl.
2K high-performance adhesive (25g)	✓
Abrasive fleece	✓
INV HEX Cover (Protective hood) Order no.: 108465001	X

#### Note:

The material and the thickness of the excited surface influence the efficiency and the frequency range.

The installation instructions must be observed for standard installations. Special installations after consultation with the sales consultant.